

Product data sheet

Specifications



Altivar Soft Starter ATS130, 105A, 200 to 480V AC, control supply 24V DC

ATS130N2C11LT

Product availability: Stock - Normally stocked in distribution facility

Main

Range of Product	Altivar Soft Starter ATS130
Product or Component Type	Soft starter
Product destination	Asynchronous motors
Product Specific Application	Simple machine
Device short name	ATS130
Phase	3 phase
Utilisation category	AC-53A
Ue power supply voltage	200...480 V - 15...10 %
power supply frequency	50...60 Hz +/- 5 Hz
[Ie] rated operational current	105 A in line 104 °F (40 °C))
Service factor at Ie	100
IP Degree of Protection	IP20
Motor power kW	30 kW 230 V normal duty 55 kW 400 V normal duty 55 kW 440 V normal duty
Maximum Horse Power Rating	30 hp 200 V normal duty 30 hp 208 V normal duty 40 hp 230 V normal duty 75 hp 460 V normal duty 75 hp 480 V normal duty

Complementary

Overload current profile	300 % Ie for 5 s
On-load factor	70 %
Operating cycles/hour	10 cyc/h
Minimum motor current	20 % Ie
Device connection	In line
[Us] control circuit voltage	24 V DC +/- 10 %
Control power	21.6 W starting and stopping 3 W steady state
Integrated motor overload protection	False
Protection type	Phase failure mains Thermal protection starter Bypass error starter Control voltage Us starter
[In] Rated current pwr loss specifctn	105 A

Price is "List Price" and may be subject to a trade discount – check with your local distributor or retailer for actual price.

Power loss static current independent	3 W
Power loss per device current dependent	27 W
Power loss during starting	703 W 300 % I _e
Standards	EN/IEC 60947-4-2 UL 60947-4-2 IEC 60664-1
Product Certifications	CE UKCA CCC RCM EAC UL
Marking	CE CCC UKCA RCM EAC
[Uc] control circuit voltage	24 V DC
Discrete input number	3
Discrete input type	DI1) digital input, 10 kOhm DI2) digital input, 10 kOhm BOOST) digital input, 10 kOhm
Input compatibility	discrete input level 1 PLC EN/IEC 61131-2
Discrete input logic	Digital input 0...< 5 V <= 0.2 mA > 13 V, >= 0.5 mA
Relay output number	1
Relay output type	Relay outputs R1A, R1C NO
Minimum switching current	2.5 mA 24 V DC relay outputs
Maximum switching current	On resistive load for relay outputs : 1 A 250 V AC 400000 cycles On resistive load for relay outputs : 1 A 30 V DC 400000 cycles On inductive load for relay outputs : 1 A 250 V AC cos phi = 0.4 100000 cycles On inductive load for relay outputs : 1 A 30 V DC cos phi = 0.4 100000 cycles
Discrete output number	1
Discrete output type	Non programmable digital output DQ1 <= 30 V 200 mA
Display type	1 LED Green)control power energized 1 LED yellow and red)motor operation phases, errors
Display screen available	False
Operating position	Vertical +/- 30 degree
Height	7.8 in (197 mm)
Width	3.2 in (81 mm)
Depth	7.09 in (180 mm)
Product Weight	5.07 lb(US) (2.3 kg)
Suitable for mounting onto standard rails	True
Function Available	Deceleration voltage ramp Boost
internal bypass	True
material declaration	True

Environment

Pollution degree	Level 2
-------------------------	---------

environmental class (during operation)	Without salt mist 3C3 IEC 60721-3-3 3S3 IEC 60721-3-3
[Uimp] rated impulse withstand voltage	4 kV
[Ui] rated insulation voltage	480 V
Electromagnetic compatibility	Conducted and radiated emissions level B conforming to IEC 60947-4-2 Short voltage interruptions level 3 conforming to IEC 61000-4-11 Electrostatic discharge level 2 conforming to IEC 61000-4-2 Radiated radio-frequency electromagnetic field immunity test level 1 conforming to IEC 61000-4-3 Electrical fast transient/burst immunity test level 2 conforming to IEC 61000-4-4 Oscillatory waves immunity level 3 conforming to IEC 61000-4-12 Voltage/current impulse level 2 conforming to IEC 61000-4-5 Conducted disturbances, induced by radiofrequency fields level 1 conforming to IEC 61000-4-6
Ambient air temperature for operation	14...104 °F (-10...40 °C) (without derating) 104...140 °F (40...60 °C) (with current derating of 2 % per °C)
Ambient Air Temperature for Storage	-13...158 °F (-25...70 °C)
Ambient air transport temperature	-40...158 °F (-40...70 °C)
Operating altitude	0...3280.84 ft (0...1000 m) without derating 3280.84...13123.36 ft (1000...4000 m) 1 % per 100 m
Relative humidity	5...95 % non condensing without dripping water IEC 60068-2-3
Maximum acceleration under vibrational stress (during operation)	10 m/s ² at 9...200 Hz
Maximum acceleration under vibratory load (during storage)	10 m/s ² at 9...200 Hz
Maximum acceleration under vibratory load (during transport)	10 m/s ² at 9...200 Hz
Maximum deflection under vibratory load (during operation)	3 mm at 2-9 Hz
Maximum deflection under vibratory load (during storage)	3 mm at 2-9 Hz
Maximum deflection under vibratory load (during transport)	3 mm at 2-9 Hz
Maximum acceleration under shock impact (during operation)	100 m/s ² at 11 ms
Maximum acceleration under shock load (during storage)	100 m/s ² at 11 ms
Maximum acceleration under shock load (during transport)	100 m/s ² at 11 ms

Ordering and shipping details

Category	US10I1122392
Discount Schedule	0I11
GTIN	3606486007440
Returnability	Yes
Country of origin	DE

Packing Units

Unit Type of Package 1	PCE
Nbr. of units in pkg.	1
Package 1 Height	3.661 in (9.300 cm)
Package 1 Width	10.630 in (27.000 cm)
Package 1 Length	11.024 in (28.000 cm)
Package weight(Lbs)	5.617 lb(US) (2.548 kg)

Unit Type of Package 2	S03
Number of Units in Package 2	3
Package 2 Height	11.811 in (30.000 cm)
Package 2 Width	11.811 in (30.000 cm)
Package 2 Length	15.748 in (40.000 cm)
Package 2 Weight	18.071 lb(US) (8.197 kg)

Contractual warranty

Warranty (in months)	18
-----------------------------	----



Environmental Data

Schneider Electric aims to achieve Net Zero status by 2050 through supply chain partnerships, lower impact materials, and circularity via our ongoing “Use Better, Use Longer, Use Again” campaign to extend product lifetimes and recyclability.

[Environmental Data explained >](#)

[How we assess product sustainability >](#)



Environmental footprint

Total lifecycle Carbon footprint	252 kg CO2 eq.
Carbon footprint of the manufacturing phase [A1 to A3]	163 kg CO2 eq.
Carbon footprint of the distribution phase [A4]	0.3 kg CO2 eq.
Carbon footprint of the installation phase [A5]	0 kg CO2 eq.
Carbon footprint of the use phase [B2, B3, B4, B6]	88 kg CO2 eq.
Carbon footprint of the end-of-life phase [C1 to C4]	0.4 kg CO2 eq.
Environmental Disclosure	Product Environmental Profile

Use Better



Materials and Substances

Packaging made with recycled cardboard	Yes
Packaging without single use plastic	Yes
EU RoHS Directive	Compliant
REACH Regulation	Free of Substances of Very High Concern above the threshold
California proposition 65	WARNING: This product can expose you to chemicals including: Lead and lead compounds, which is known to the State of California to cause cancer and birth defects or other reproductive harm. For more information go to www.P65Warnings.ca.gov

Use Longer



Lifetime extension

Repair	No
--------	----

Use Again



Repack and remanufacture

Recyclability potential, in %	63
Circularity Profile	End of Life Information
Take-back	No
WEEE Label	 The product must be disposed on European Union markets following specific waste collection and never end up in rubbish bins.

Dimensions Drawings

Dimensions

Soft Starter

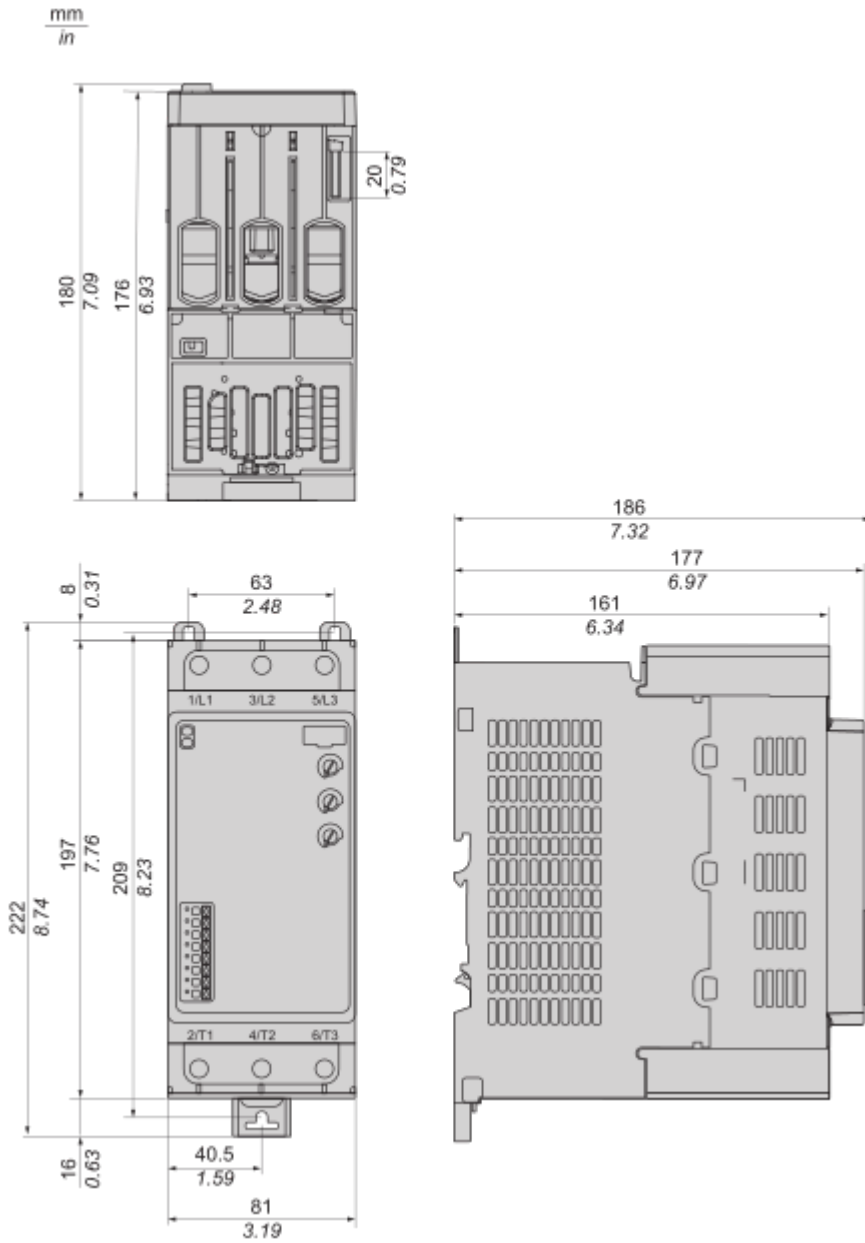

Dimensions

Soft Motor Starter

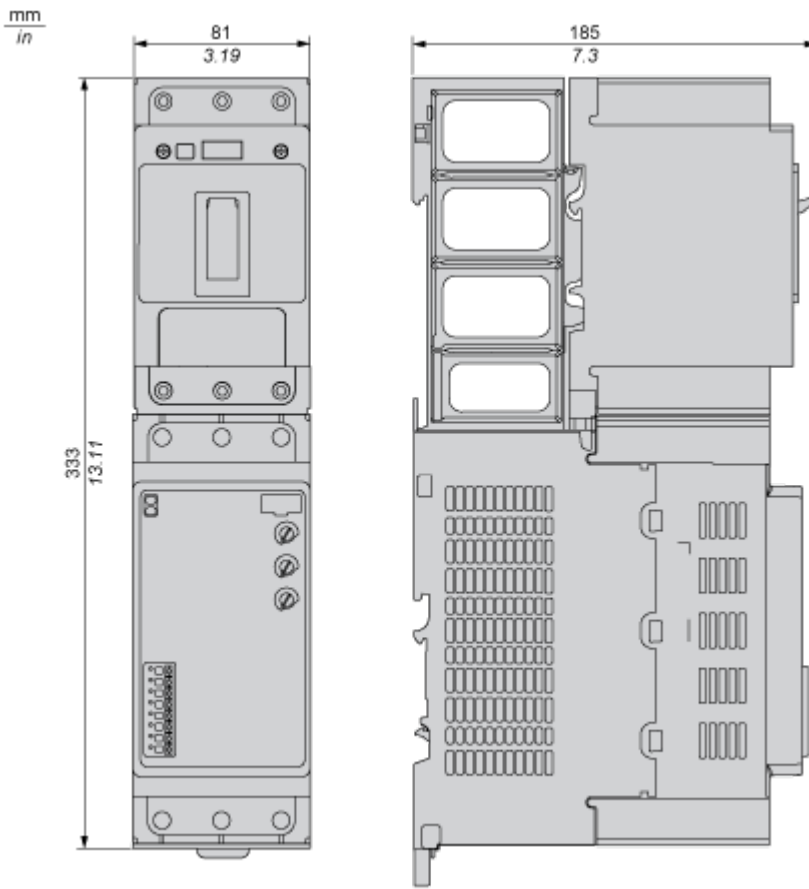

Mounting and Clearance

Mounting

ATS130 Standalone

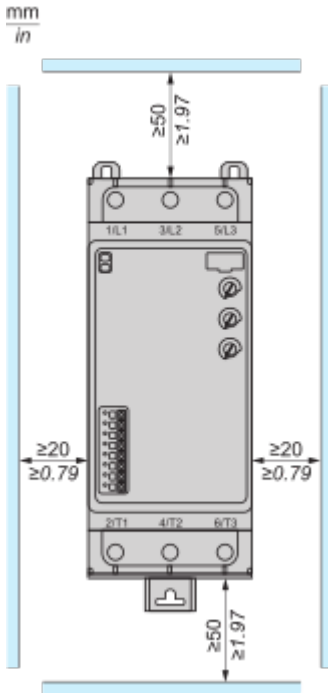

ATS130 Side by side

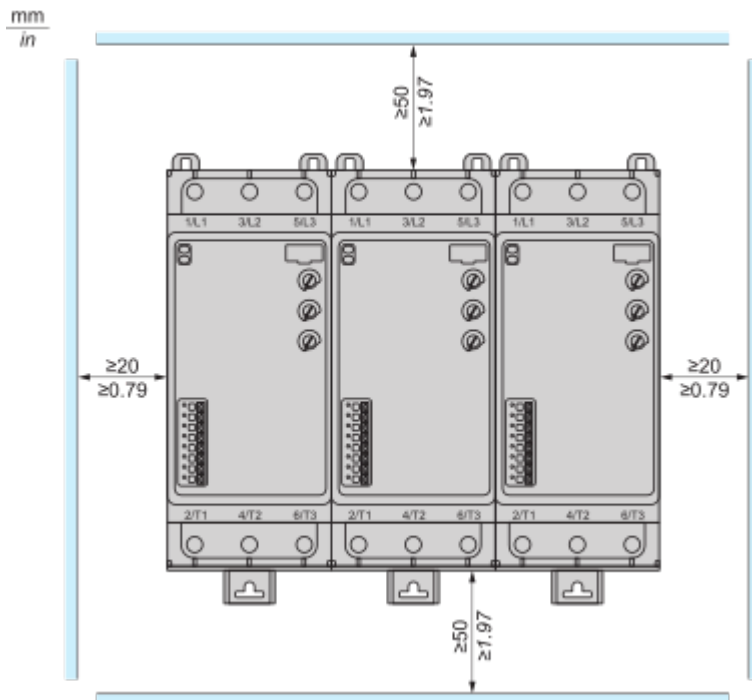

ATS130 Soft Motor Starter (ATS130 + TeSys Deca circuit breaker)

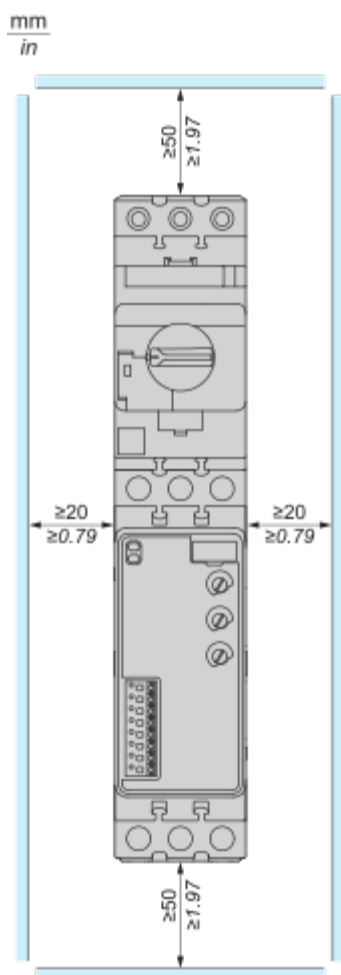

Wiring

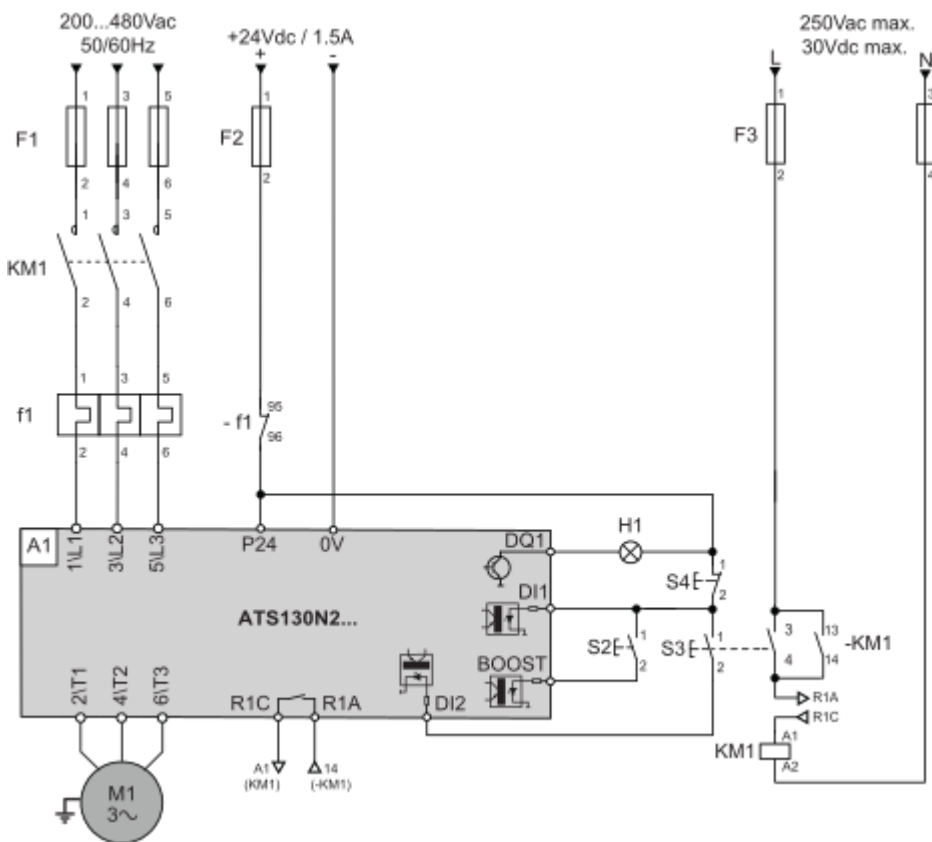

NOTE: Set the potentiometer **Stop Time (s)** to 0 to get a freewheel.

Designation	Component	Description
F1	Fuses	Short circuit protection device for the mains
KM1	Contactor	Line contactor
-KM1	Auxiliary contact of the contactor	Auxiliary contact of the contactor on the command part
f1	Motor overload relay	Thermal protection device for the motor
- f1	Auxiliary contact of the motor overload relay	Auxiliary contact of the motor overload relay F1 inserted in the control circuit
F2	Fuse	Short circuit protection of the 24Vdc control supply
F3	Fuses	Short circuit protection of the control supply
S2	Normally open contact push-button.	RUN command for BOOST command
S3	Normally open contact push-button.	RUN command for 3-wire control
S4	Normally closed contact push-button	STOP command for 3-wire control

Designation	Component	Description
H1	Light	Presence of current

Offer Marketing Illustration

Product benefits / Features

Technical Benefits
Altivar Soft Starter ATS130



Offer Marketing Illustration

Product benefits / Features

The image is a green graphic titled "Features Altivar Soft Starter ATS130". It features two black electrical units in the center. Surrounding them are six circular icons, each with a text label below it:

- Quick and easy installation:** Represented by a clock icon with a checkmark.
- Compact products and solutions:** Represented by two overlapping document icons.
- Preventive maintenance free:** Represented by a hand holding a magnifying glass over a document.
- Easy product identification and support:** Represented by a smartphone icon with signal waves.
- Extended operation cycle:** Represented by a circular arrow icon.
- Flexibility:** Represented by a spring icon.

Image of product / Alternate images

Alternative



