

# ABLP1A24045

Regulated Power Supply, modicon power supply, 100...240V AC, 24V, 4.5A, single phase, Panel Mount

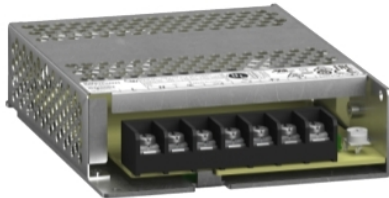

## Main

Range of Product	Modicon Power Supply
Product or Component Type	Power supply
Power supply type	Regulated switch mode
Variant option	Panel mount
Enclosure Material	Aluminum
Nominal input voltage	100...240 V AC single phase
Kw Rating	100 W
Output voltage	24 V DC
Power supply output current	4.5 A

## Complementary

Efficiency at full load	90...264 V AC
Nominal network frequency	50...60 Hz
Network system compatibility	TN TT IT
Maximum leakage current	1 mA 240 V AC
Input protection type	Integrated fuse (not interchangeable) 4 A
Inrush current	45 A 115 V 85 A 230 V
Power factor	0.55 at 115 V AC 0.45 at 230 V AC
Efficiency	89 % 230 V AC
Output voltage adjustment	21.6...26.4 V
Power dissipation in W	20 W
Current consumption	< 2.3 A 115 V AC < 1.5 A 230 V AC
Turn-on time	< 500 ms
Holding time	> 20 ms 115 V AC > 40 ms 230 V AC
Startup with capacitive loads	4000 µF
Residual ripple	< 150 mV
Meantime between failure [MTBF]	700000 h at 77 °F (25 °C), full load conforming to SR 332
Output protection type	Against overload and short-circuits automatic reset Against over temperature manual reset Against overvoltage manual reset
Connections - terminals	Screw connection 0.75...2.5 mm <sup>2</sup> , AWG 18...AWG 14) without wire end ferrule Screw connection 0.75...1.5 mm <sup>2</sup> , AWG 18...AWG 16) with wire end ferrule
Line and load regulation	< 0.5 % network 0 to 100 % load at 77 °F (25 °C) < 1 % network full voltage range in line at 77 °F (25 °C)
Status LED	1 LED (Green) output voltage
Depth	5.08 in (129 mm)
Height	1.18 in (30 mm)
Width	3.82 in (97 mm)
Net Weight	0.66 lb(US) (0.3 kg)
Output coupling	Parallel Serial

Mounting support	Top hat type TH35-15 rail IEC 60715 Top hat type TH35-7.5 rail IEC 60715 Double-profile DIN rail Panel mounting
Supply	SELV IEC 60950-1 SELV IEC 60204-1 SELV IEC 60364-4-41
Dielectric strength	3750 V AC with input to output
Service life	10 year(s)
Overvoltage category	II

## Environment

Standards	IEC 62368-1 IEC 61010-1 EN 61010-2-201 EN 61204-3 IEC 61000-6-1 IEC 61000-6-2 IEC 61000-6-3 IEC 61000-6-4 IEC 61000-3-2 EN 61000-3-3 UL 62368-1 UL 61010-1 UL 61010-2-201 CSA C22.2 No 62368-1 CSA C22.2 No 61010-1 CSA C22.2 No 61010-2-201 EN/IEC 62368-1
Product certifications	CE[RETURN]CULus[RETURN]EAC[RETURN]RCM[RETURN]CB Scheme[RETURN]KC
Operating altitude	5000 m
Shock resistance	150 m/s <sup>2</sup> 11 ms
IP degree of protection	IP10
Ambient air temperature for operation	-22...122 °F (-30...50 °C) without derating mounting position A, B, F, G < 6561.68 ft (2000 m) 122...158 °F (50...70 °C) with current derating of 2 % per °C mounting position A, B, F, G < 6561.68 ft (2000 m)
Electrical shock protection class	Class I
Pollution degree	2
Vibration resistance	3 mm 2...9 Hz)IEC 60068-2-6 10 m/s <sup>2</sup> 9...200 Hz)IEC 60068-2-6
Electromagnetic immunity	Immunity to electrostatic discharge - test level: 8 kV (contact discharge) conforming to IEC 61000-4-2 Immunity to electrostatic discharge - test level: 15 kV (air discharge) conforming to IEC 61000-4-2 Immunity to conducted RF disturbances - test level: 15 V/m (80 MHz...2 GHz) conforming to IEC 61000-4-3 Immunity to conducted RF disturbances - test level: 5 V/m (2...2.7 GHz) conforming to IEC 61000-4-3 Immunity to conducted RF disturbances - test level: 5 V/m (2.7...6 GHz) conforming to IEC 61000-4-3 Immunity to fast transients - test level: 4 kV (on input-output) conforming to IEC 61000-4-4 Surge immunity test - test level: 4 kV (between power supply and earth) conforming to IEC 61000-4-5 Surge immunity test - test level: 3 kV (between phases) conforming to IEC 61000-4-5 Immunity to conducted RF disturbances - test level: 15 V (0.15...80 MHz) conforming to IEC 61000-4-6 Immunity to magnetic fields - test level: 30 A/m (50...60 Hz) conforming to IEC 61000-4-8 Immunity to voltage dips conforming to IEC 61000-4-11 Disturbing field emission conforming to EN 55016-2-3 Limits for harmonic current emissions conforming to IEC 61000-3-2 Conforming to EN 55016-1-2 Conforming to EN 55016-2-1
Electromagnetic emission	Conducted emissions IEC 61000-6-3 Radiated emissions IEC 61000-6-4

## Ordering and shipping details

Category	22524-ABL1 DEDICATED POWER SUPPLIES
Discount Schedule	CP12
GTIN	3606481500281
Returnability	Yes
Country of origin	CN

## Packing Units

Unit Type of Package 1	PCE
Number of Units in Package 1	1
Package 1 Height	1.57 in (4.000 cm)
Package 1 Width	5.83 in (14.800 cm)
Package 1 Length	7.28 in (18.500 cm)
Package 1 Weight	14.85 oz (421.000 g)
Unit Type of Package 2	S03
Number of Units in Package 2	19
Package 2 Height	11.81 in (30.000 cm)
Package 2 Width	11.81 in (30.000 cm)
Package 2 Length	15.75 in (40.000 cm)
Package 2 Weight	18.52 lb(US) (8.400 kg)

## Offer Sustainability

Sustainable offer status	Green Premium product
California proposition 65	WARNING: This product can expose you to chemicals including: Lead and lead compounds, which is known to the State of California to cause cancer and birth defects or other reproductive harm. For more information go to <a href="http://www.P65Warnings.ca.gov">www.P65Warnings.ca.gov</a>
REACH Regulation	<a href="#">REACH Declaration</a>
EU RoHS Directive	Pro-active compliance (Product out of EU RoHS legal scope)
Mercury free	Yes
China RoHS Regulation	<a href="#">China RoHS Declaration</a>
RoHS exemption information	<a href="#">Yes</a>
Environmental Disclosure	<a href="#">Product Environmental Profile</a>
Circularity Profile	<a href="#">End Of Life Information</a>
WEEE	The product must be disposed on European Union markets following specific waste collection and never end up in rubbish bins.

Electrical Safety

- If the unit is use in a manner not specified by the manufacturer, the protection provided by the equipment may be impaired.
- For means of disconnection a switch or circuit breaker, located near the product, must be included in the installation. A marking as disconnecting device for the product is required.
- The device has an internal fuse. The unit is tested and approved with branch circuit protective device up to 20A. This circuit breaker can be used as disconnecting device.
- The power supply is only suitable for audio, video, information, communication, industrial and control equipment.

Dimensions

Front and Side Views

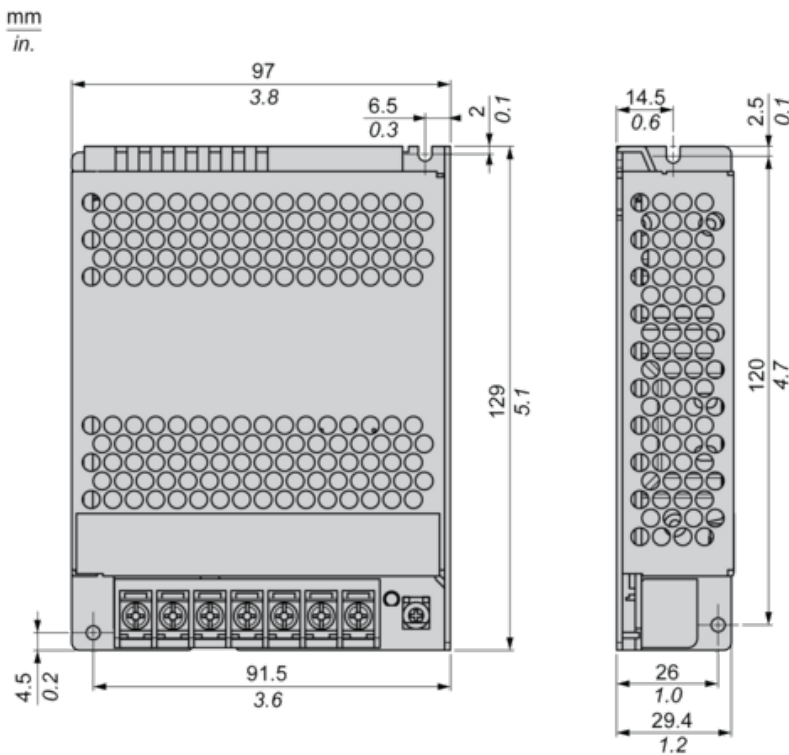

Connections and Schema

Correct Parallel Connection

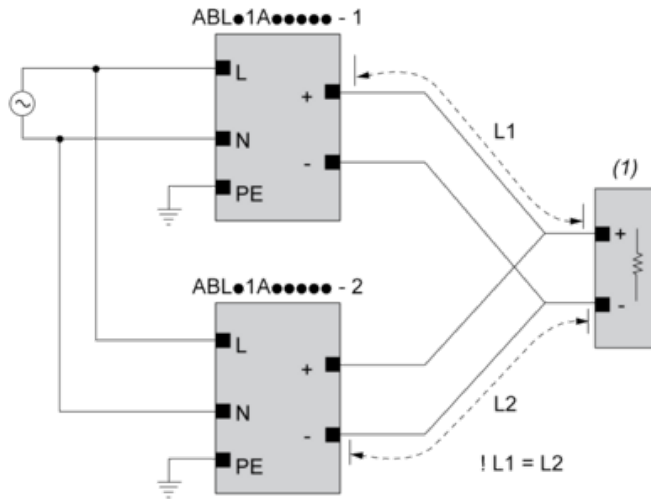

(1) : Load

Incorrect Parallel Connection

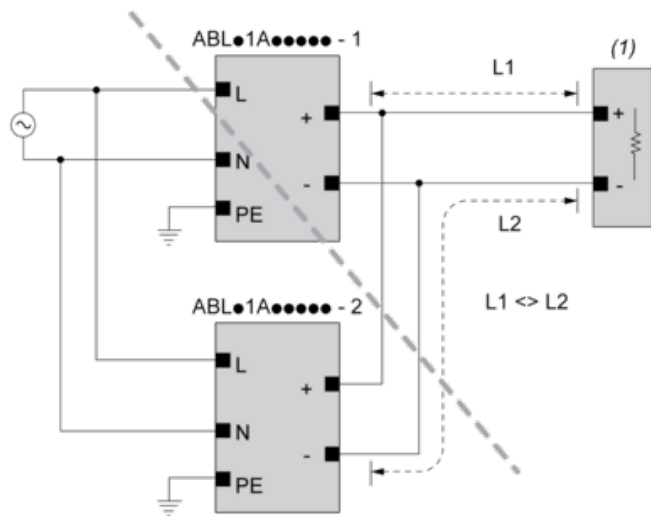

(1) : Load

ABLx1Axxxxx-1 = ABLx1Axxxxx-2

max 2 x ABLx1Axxxxx

L1 = L2

$\Delta V$  max 25 mV

$I_{Load} < 90\% \cdot 2 \cdot I_{nom}$

## Output Voltage Balancing

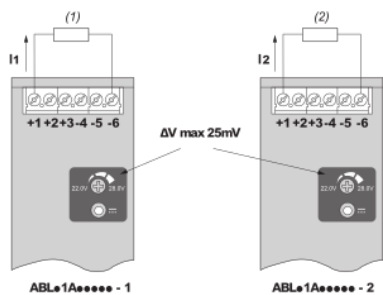

(1) :  $R_{\text{Load1}}$

(2) :  $R_{\text{Load2}}$

$R_{\text{Load1}} = R_{\text{Load2}}$

$I_1 = I_2 = \sim I_{\text{nom}}$

## Series Connection

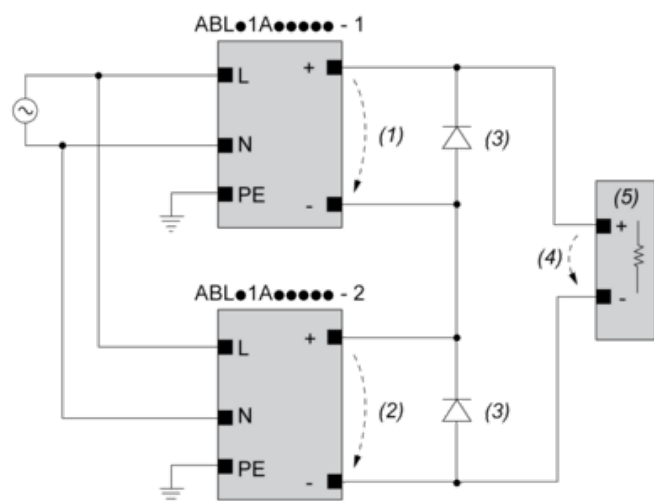

(1) :  $V_{\text{out1}}$

(2) :  $V_{\text{out2}}$

(3) : 2 x Diode,  $V_{\text{RRM}} > 2 \times V_{\text{out1/2}}$ ,  $I_{\text{F}} > 2 \times I_{\text{nom1/2}}$

(4) :  $V_{\text{Load}} = 2 \times V_{\text{out}}$

(5) : Load

## Connections and Schema

	(1)		
	<40°C	<50°C	<70°C
ABLP1A12085	60°C	70°C	90°C
ABLP1A24045	60°C	70°C	90°C
ABLP1A24062	60°C	70°C	90°C
ABLP1A24100	60°C	70°C	90°C

(1) : Ambient

Mounting

Mounting Position A

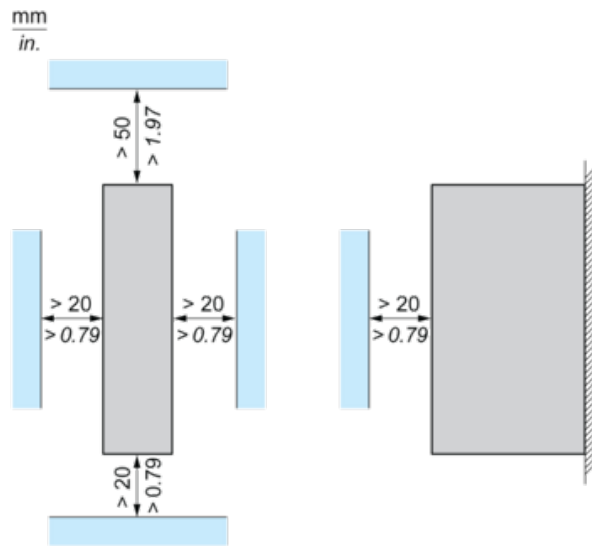

Mounting Position B

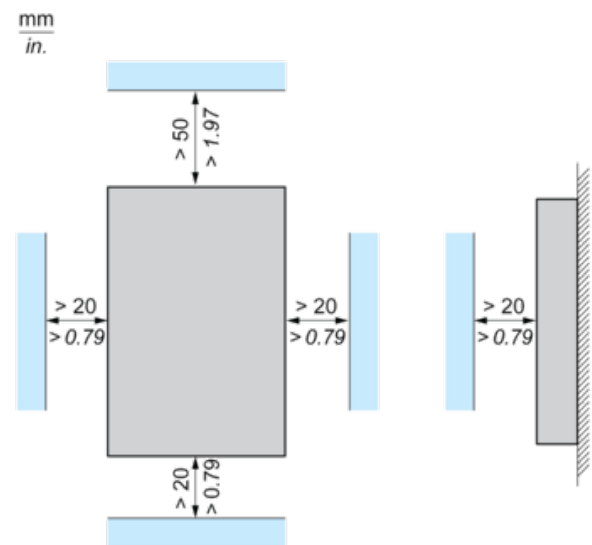

Mounting Position C

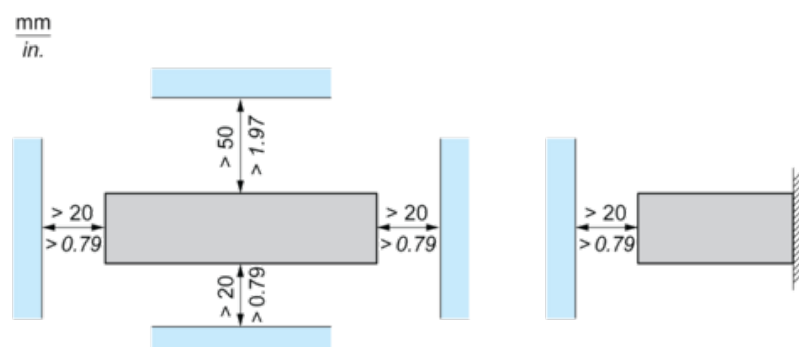

### Mounting Position F

$\frac{\text{mm}}{\text{in.}}$

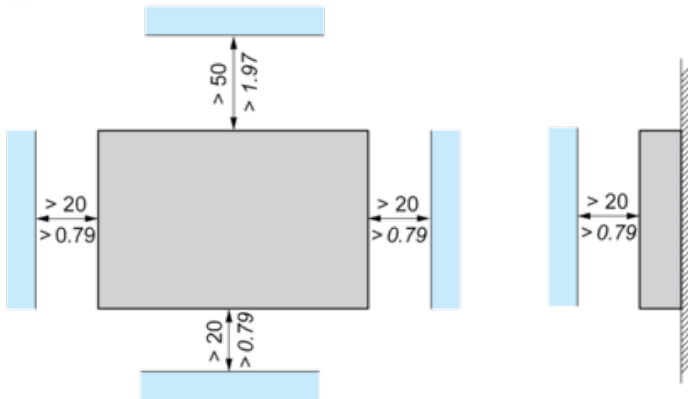

### Mounting Position G

$\frac{\text{mm}}{\text{in.}}$

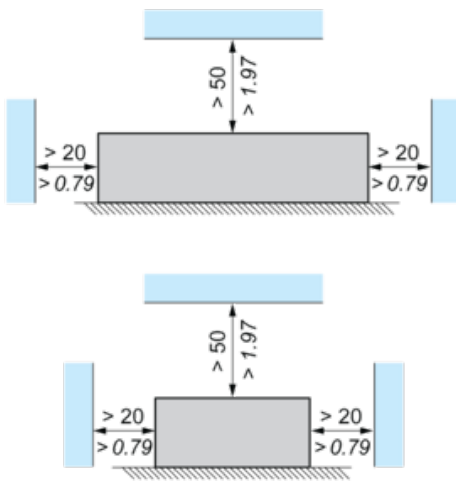

### Mounting Position H

$\frac{\text{mm}}{\text{in.}}$

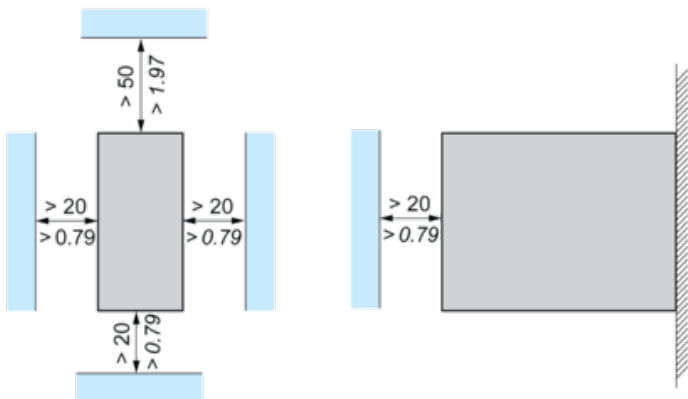

Performance Curves

Mounting Position A, B, F and G

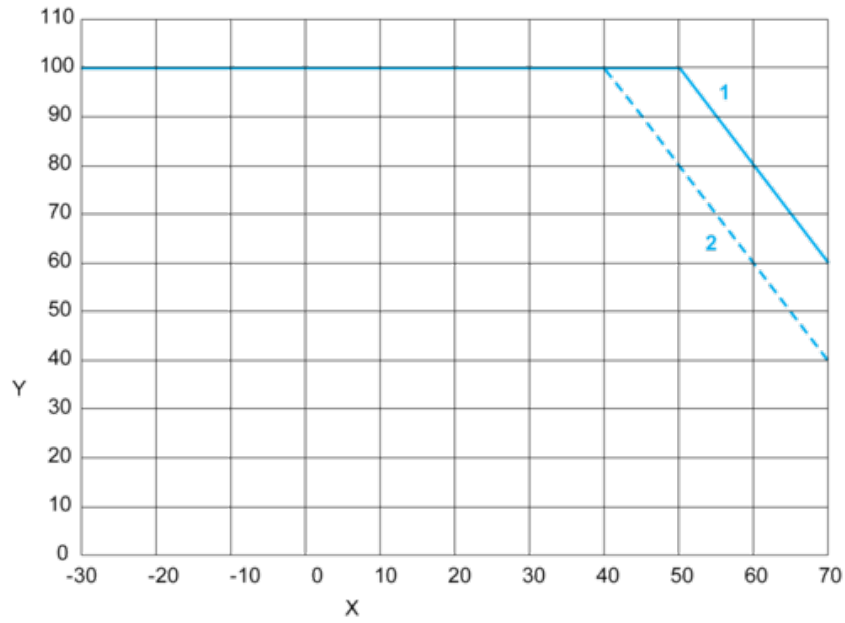

Mounting Position C

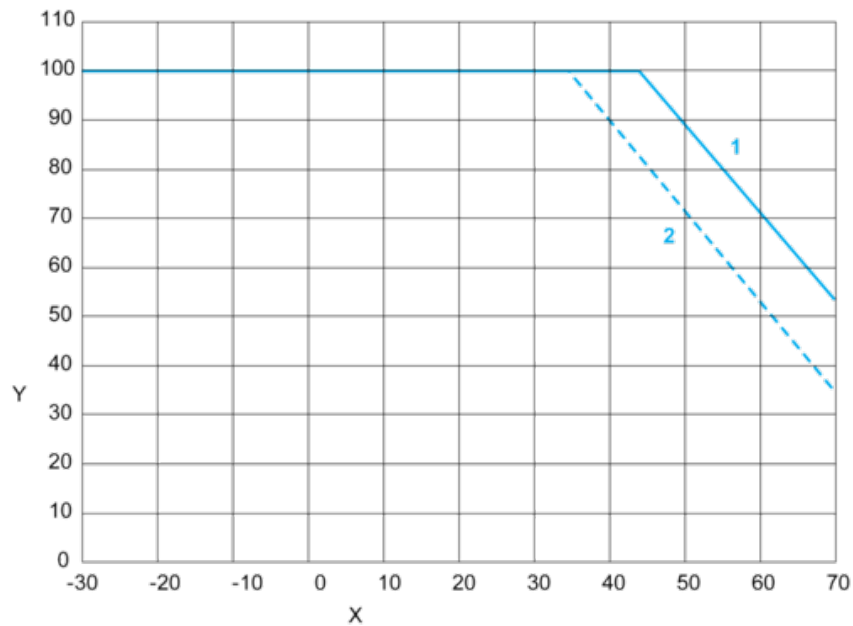

## Mounting Position H

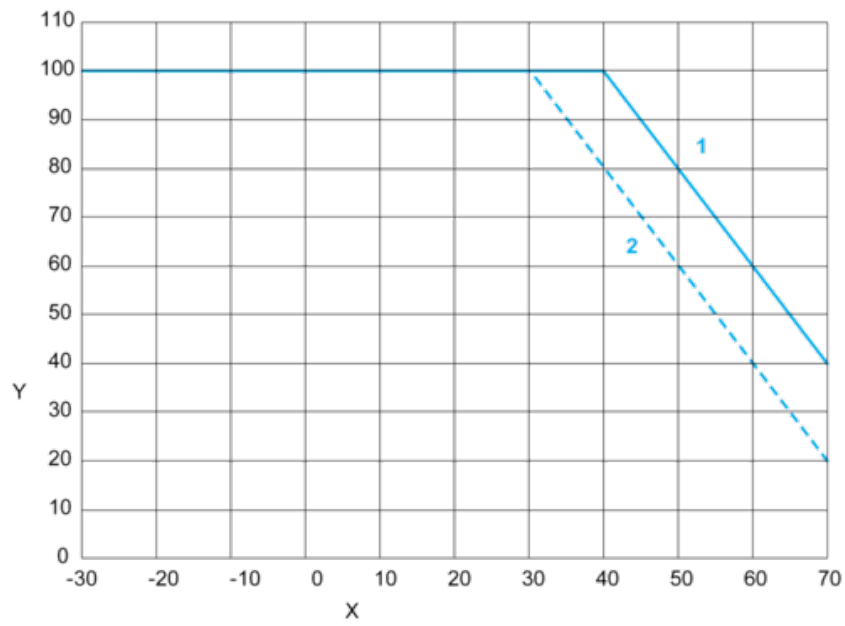

X : Surrounding Air Temperature (°C)

Y : Percentage of Max Load (%)

1 : Altitude 2000 m

2 : Altitude 5000 m

Note : < 115 VAC additional derating by 0.6% / V